

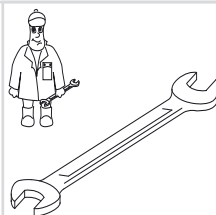

Gebr. Becker GmbH
Hölker Feld 29-31
D-42279 Wuppertal

Wartung
Maintenance
Entretien
Manutenzione
Mantenimiento



	Pos.	Menge Quantity Quantité Quantità Cantidad	Bestell-Nr. Ident No. No. Identification No. Identificazione No. de pedido	Bezeichnung Description Designation Designazione Descripción
SV 8.130	125	1*	909568 00000	Filterpatrone, Filter cartridge, Cartouche Filtrante, Cartuccia filtro, Cartucho de filtro

* erforderlich / necessary / nécessaire / necessaria / necesaria (F / DSF / VSF)



Ersatzteilliste
Spare parts list
Liste de pièces de rechange
Listino pezzi di ricambio
Lista de piezas de recambio
Lista de peças sobresselentes
Reserveonderdelenlijst
Reservedelsliste
Reservdelslista

Reservedelsliste
Varaosaluettelo
Wykaz części zamiennych
Seznam náhradních dílů
Tartalékalkatrész lista
Κατάλογος ανταλλακτικών
Перечень запасных частей
备用零件目录
スペアパーツリスト

SV 8.130

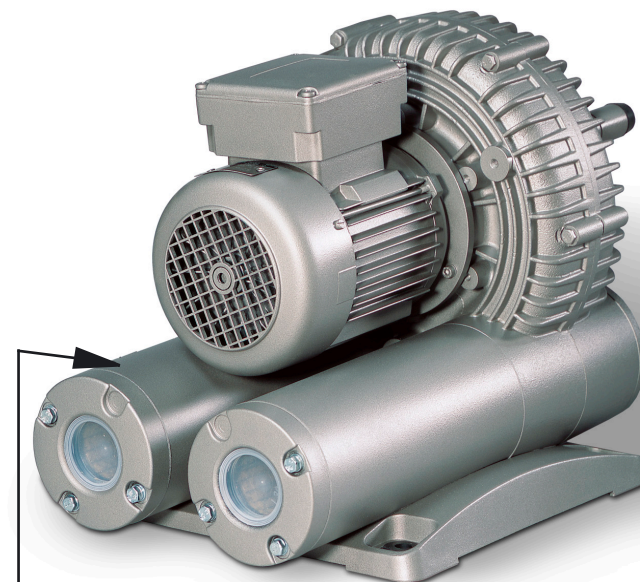

28000028600 11/2009

Index-B

SERVICE

BECKER
D-42279 Wuppertal
www.becker-international.com

CE

year XXXX

No. **B**

type **SV 8.130-XX**

frequency XXXX Hz

speed XXXX min⁻¹

power required XXXX kW

inlet capacity XXXX m³/h

pressure + XXXX mbar

vacuum - XXXX mbar

Made in Germany

Index Option

D Service:

Tel: +49 (0)202 697-171

Fax: +49 (0)202 64 44 74

E-Mail: info@becker-international.com

www.becker-international.com

Pos.	Bestell Nr.	Beschreibung	
8	570400 30200	UMBAUSATZ /1⇒ /2 (POS: 64, 69, 119, 181, 183)	
12	515101 30200	FUSS - SEITLICH, KOMPLETT	
14	515103 30200	GERÄTEFUSS, KOMPLETT (3x) ¹⁾	
27	000100 30200	GEHÄUSE	
29	911304 00000	DICHTUNGSSCHLAUCH	
34	064900 30200	ZENTRIERBUCHSE	
48	947738 00000	PASSFEDER	
49	000602 30200	LAUFRAD	
50	013900 30200	DISTANZBUCHSE	
51	911432 00000	DISTANZSCHEIBE 25x33x0,2	
52	911431 00000	DISTANZSCHEIBE 25x33x0,1	
53	911429 00000	DISTANZSCHEIBE 25x33x0,05	
54	911428 00000	DISTANZSCHEIBE 25x33x0,025	
55	906612 50000	WÄLZLAGER	
56	016800 30200	SPANNSCHEIBE	
57	901805 00000	WELLENENDSCHRAUBE	
63	000200 30200	GEHÄUSEDECKEL	
64	951703 00000	FEDERSCHEIBE	
65	945325 00000	INNENSECHSKANTSCHRAUBE	
69	005600 30200	DECKEL	
70	005602 30200	DECKEL	
72	945222 00000	SECHSKANTSCHRAUBE	
75	001102 30200	LAGERDECKEL	
76	948503 00000	FEDERRING	
77	945215 00000	SECHSKANTSCHRAUBE	
78	928602 70000	DRUCKFEDER	
79	917520 00000	PASSSCHEIBE	
101	007400 19600	SCHALLDÄMPFERGEHÄUSE	
102	907600 60000	SIEBROHR	
103	907701 70000	DÄMPFER	
104	907500 30200	DICHTUNG	
105	007803 30200	GEWINDEFLENSCH	
107	949451 00000	UNTERLEGSCHHEIBE	
108	003803 94000	ZUGANKERSCHRAUBE	
109	903811 01000	ZUGANKERSCHRAUBE	
113	040100 30200	FILTERGEHÄUSE	
115	945321 00000	INNENSECHSKANTSCHRAUBE	
116	945225 00000	SECHSKANTSCHRAUBE	
119	945376 00000	INNENSECHSKANTSCHRAUBE	
125	909568 00000	FILTERPATRONE (1x) ¹⁾	
126	951007 00000	STIFTSCHRAUBE	
127	040200 19700	FILTERDECKEL	
133	921503 00000	STERNGRIF	
135	040201 19700	FILTERDECKEL	
138	945373 00000	INNENSECHSKANTSCHRAUBE	
139	016600 19600	ANSCHLUSSSTÜCK	
181	015500 30200	REDUZIERSTÜCK	
183	005601 30200	DECKEL	
201	015100 30200	FUSS	
202	947504 00000	UNTERLEGSCHHEIBE	
203	945223 00000	SECHSKANTSCHRAUBE	
204	015101 30200	FUSS-SEITLICH	
206	945320 00000	INNENSECHSKANTSCHRAUBE	
209	951906 00000	KABELTÜLLE	
211	946944 00000	STIFTSCHRAUBE	
213	012400 30200	ZWISCHENSTÜCK	
215	741315 00000	GUMMIPUFFER	
216	015101 79000	FUSS	
301	007401 19600	SCHALLDÄMPFERGEHÄUSE	

Pos.	Bestell Nr.	Beschreibung	
302	907600 70100	SIEBROHR	
303	907702 10000	DÄMPFER	
316	903803 01000	ZUGANKERSCHRAUBE	
400.1	733700 99581	VENTILEINSATZ, < 0,17BAR	
400.2	733701 99581	VENTILEINSATZ, < 0,28BAR	
400.3	733702 99581	VENTILEINSATZ, < 0,42BAR	

Variante	/1-05 /2-05	MIT KORROSIONSSCHUTZ ²⁾
	69	570410 30200 005610 30200
	181	015510 30200
	183	005611 30200
		570210 30200
	27	000110 30200
	49	000612 30200
	63	000210 30200
	70	005612 30200
		574310 30200
	113	040110 30200
	301	007411 19600
		574311 30200
	113	040110 30200
	139	016610 19600
	301	007411 19600
		573310 30200
	101	007410 19600
		574313 30200
	113	040110 30200
	139	016610 19600

Variante	/1-401 /2-401	MIT FREQUENZUMRICHTER ²⁾
	49	570500 30200 000603 30200
	65	945254 00000
		573304 30200
	105	007801 30200
	413	796302 41115
	415	503603 41100

¹⁾ erforderliche Bestellmenge / Wartung (F / DSF / VSF)

²⁾ variantenabhängige Bauteile

Zeichnung - siehe Anhang 

Pos.	Ident No.	Description
8	570400 30200	CONVERSION SET /1⇒ /2 (POS: 64, 69, 119, 181, 183)
12	515101 30200	FOOT - LATERAL, COMPLETE
14	515103 30200	FOOT, COMPLETE (3x) ¹⁾
27	000100 30200	PUMP HOUSING
29	911304 00000	RUBBER SEAL RING
34	064900 30200	CENTRING BUSH
48	947738 00000	KEY
49	000602 30200	IMPELLER WHEEL
50	013900 30200	SPACER SLEEVE
51	911432 00000	SPACER 25X33X0,2
52	911431 00000	SPACER 25X33X0,1
53	911429 00000	SPACER 25X33X0,05
54	911428 00000	SPACER 25X33X0,025
55	906612 50000	ANTIFRICTION BEARING
56	016800 30200	IDLER
57	901805 00000	SHAFT END SCREW
63	000200 30200	HOUSING LID
64	951703 00000	LOCKING WASHER
65	945325 00000	HEXAGONAL SOCKET HEAD SCREW
69	005600 30200	COVER
70	005602 30200	LID
72	945222 00000	HEX HEAD SCREW
75	001102 30200	BEARING CAP
76	948503 00000	LOCK WASHER
77	945215 00000	HEX HEAD SCREW
78	928602 70000	PRESSURE SPRING
79	917520 00000	SHIM RING
101	007400 19600	SILENCER HOUSING
102	907600 60000	STRAINER TUBE
103	907701 70000	SILENCER SPONGE
104	907500 30200	GASKET
105	007803 30200	SCREWED FLANGE
107	949451 00000	WASHER
108	003803 94000	ANCHORING SCREW
109	903811 01000	ANCHORING SCREW
113	040100 30200	FILTER HOUSING
115	945321 00000	SOCKET HEAD SCREW
116	945225 00000	HEX-HEAD SCREW
119	945376 00000	SOCKET HEAD SCREW
125	909568 00000	FILTER CARTRIDGE (1x) ¹⁾
126	951007 00000	STUD
127	040200 19700	FILTER COVER
133	921503 00000	STAR GRIP
135	040201 19700	FILTER COVER
138	945373 00000	SOCKET HEAD SCREW
139	016600 19600	CONNECTING PIECE
181	015500 30200	REDUCING PIECE
183	005601 30200	COVER
201	015100 30200	FOOT
202	947504 00000	WASHER
203	945223 00000	HEX-HEAD SCREW
204	015101 30200	FOOT
206	945320 00000	SOCKET HEAD SCREW
209	951906 00000	RUBBER BUSHING
211	946944 00000	STUD
213	012400 30200	INTERMEDIATE PIECE
215	741315 00000	RUBBER BUFFER
216	015101 79000	FOOT
301	007401 19600	SILENCER HOUSING



Pos.	Ident No.	Description
302	907600 70100	STRAINER TUBE
303	907702 10000	SILENCER MATERIAL
316	903803 01000	ANCHORING SCREW
400.1	733700 99581	VALVE CORE, < 0,17BAR
400.2	733701 99581	VALVE CORE, < 0,28BAR
400.3	733702 99581	VALVE CORE, < 0,42BAR



/1-05 /2-05	WITH CORROSION PROTECTION ²⁾	
	570410 30200	CONVERSION KIT /1⇒ /2
69	005610 30200	- CAP
181	015510 30200	- REDUCING PIECE
183	005611 30200	- CAP
	570210 30200	BLOWER / VACUUM PUMP
27	000110 30200	- PUMP BODY
49	000612 30200	- IMPELLER
63	000210 30200	- HOUSING LID
70	005612 30200	- CAP
	574310 30200	SILENCER WITH FILTER
113	040110 30200	- FILTER HOUSING
301	007411 19600	- SILENCER HOUSING
	574311 30200	SILENCER WITH VALVE CORE
113	040110 30200	- FILTER HOUSING
139	016610 19600	- CONNECTING PIECE
301	007411 19600	- SILENCER HOUSING
	573310 30200	SILENCER
101	007410 19600	- SILENCER HOUSING
	574313 30200	SILENCER WITH VALVE CORE + FILTER
113	040110 30200	- FILTER HOUSING (2x)
139	016610 19600	- CONNECTING PIECE

/1-401 /2-401	WITH FREQUENCY INVERTER ²⁾	
	570500 30200	BLOWER / VACUUM PUMP
49	000603 30200	- IMPELLER
65	945254 00000	- WASHER
	573304 30200	SILENCER
105	007801 30200	- SCREWED FLANGE
413	796302 41115	FREQUENCY INVERTER (4,0KW)
415	503603 41100	ADAPTER PLATE

¹⁾ necessary order quantity / maintenance (F / DSF / VSF)

²⁾ variant-dependent components

Drawing - see appendix

Pos.	No. Identification	Designation
		
8	570400 30200	ÉQUIPEMENT DE CONVERSION /1⇒ /2 (POS: 64, 69, 119, 181, 183)
12	515101 30200	PIED - LATÉRAL, COMPLET
14	515103 30200	PIED, COMPLET (3x) ¹⁾
27	000100 30200	CARTER
29	911304 00000	JOINT
34	064900 30200	BAGUE DE CENTRAGE
48	947738 00000	CLAVETTE
49	000602 30200	ROUE À AUBAGES
50	013900 30200	DOUILLE D'ÉCARTEMENT
51	911432 00000	DISQUE AJUSTAGE 25X33X0,2
52	911431 00000	DISQUE AJUSTAGE 25X33X0,1
53	911429 00000	DISQUE AJUSTAGE 25X33X0,05
54	911428 00000	DISQUE AJUSTAGE 25X33X0,025
55	906612 50000	ROULEMENT A BILLES
56	016800 30200	POULIE DE TENSION
57	901805 00000	VIS SIX-PANS
63	000200 30200	COUVERCLE DE CARTER
64	951703 00000	RONDELLE À RESSORT
65	945325 00000	VIS HEXAGONALE INTERNE
69	005600 30200	COUVERCLE
70	005602 30200	COUVERCLE
72	945222 00000	VIS SIX-PANS
75	001102 30200	CHAPEAU DE PALIER
76	948503 00000	RONDELLE ÉLASTIQUE
77	945215 00000	VIS SIX-PANS
78	928602 70000	RESSORT DE PRESSION
79	917520 00000	RONDELLE DE RÉGLAGE
101	007400 19600	CORPS DE LA SILENCIEUX
102	907600 60000	GRILLE POUR SILENCIEUX
103	907701 70000	MOUSSE POUR SILENCIEUX
104	907500 30200	JOINT
105	007803 30200	BRIDE FILETÉE
107	949451 00000	RONDELLE
108	003803 94000	VIS D'ANCRAGE
109	903811 01000	VIS D'ANCRAGE
113	040100 30200	BOITE POUR FILTRE
115	945321 00000	VIS HEXAGONALE INTERNE
116	945225 00000	VIS HEXAGONALE
119	945376 00000	VIS HEXAGONALE INTERNE
125	909568 00000	CARTOUCHE FILTRANTE (1x) ¹⁾
126	951007 00000	PRISONNIER
127	040200 19700	COUVERCLE DU FILTRE
133	921503 00000	POIGNEE-ETOILE
135	040201 19700	COUVERCLE DU FILTRE
138	945373 00000	VIS HEXAGONALE INTERNE
139	016600 19600	PIECE RACCORD
181	015500 30200	PIECE DE REDUCTION
183	005601 30200	COUVERCLE
201	015100 30200	PIED
202	947504 00000	RONDELLE
203	945223 00000	VIS HEXAGONALE
204	015101 30200	PIED-LATÉRAL
206	945320 00000	VIS HEXAGONALE INTERNE
209	951906 00000	PROTECTION EN CAOUTCHOUC
211	946944 00000	PRISONNIER
213	012400 30200	PLAQUE INTERMEDIARE
215	741315 00000	AMORTISSEUR EN CAOUTCHOUC
216	015101 79000	PIED
301	007401 19600	CARCASSE SILENCIEUX

Pos.	No. Identification	Designation
		
302	907600 70100	TUYAU-TAMIS
303	907702 10000	MATERIAL POUR SILENCIEUX
316	903803 01000	VIS
400.1	733700 99581	SOUPAPE, < 0,17BAR
400.2	733701 99581	SOUPAPE, < 0,28BAR
400.3	733702 99581	SOUPAPE, < 0,42BAR

Variante

/1-05 /2-05	AVEC PROT. CONTRE LA CORROSION ²⁾	
69	570410 30200 005610 30200	KIT DE TRANSFORMATION /1⇒ /2 - COUVERCLE - PIECE DE REDUCTION - COUVERCLE
181	015510 30200	
183	005611 30200	
27	570210 30200 000110 30200	SOUFFLANTE / POMPE A VIDE - CORP DE POMPE - ROUE
49	000612 30200	
63	000210 30200	
70	005612 30200	SILENCIEUX AVEC FILTRE - CARTER FILTRE
113	040110 30200	
301	007411 19600	
113	574311 30200 040110 30200	SILENCIEUX AVEC SOUPAPE - CARTER FILTRE - PIECE DE RACCORDEMENT
139	016610 19600	
301	007411 19600	
101	573310 30200 007410 19600	SILENCIEUX - CARCASSE SILENCIEUX SILENCIEUX AVEC SOUPAPE + FILTRE - CARTER FILTRE (2x) - PIECE DE RACCORDEMENT
113	574313 30200 040110 30200	
139	016610 19600	

Variante

/1-401 /2-401	AVEC CONVERTISSEUR DE FRÉQUENCE ²⁾	
49	570500 30200 000603 30200	SOUFFLANTE / POMPE A VIDE - ROUE - RONDELLE
65	945254 00000	
105	573304 30200 007801 30200	SILENCIEUX - BRIDE FILETÉE CONVERTISSEUR DE FRÉQUENCE (4,0KW) PLATINE D'ADAPTION
413	796302 41115 503603 41100	
415	503603 41100	

¹⁾ quantité nécessaire / entretien (F / DSF / VSF)

²⁾ composants variante-dependantes

plan - voir annexe



Pos.	No. Identificazione	Designazione
8	570400 30200	ATTREZZATURA PER LA TRASFORMAZIONE /1⇒ /2 (POS: 64, 69, 119, 181, 183)
12	515101 30200	PIEDE - LATERALE, COMPLETO
14	515103 30200	PIEDE, COMPLETO (3x) ¹⁾
27	000100 30200	CARCASSA
29	911304 00000	GUARNIZIONE
34	064900 30200	BOCCOLA DI CENTRAGGIO
48	947738 00000	CHIAVETTA
49	000602 30200	RUOTA A PALETTE
50	013900 30200	ANELLO DISTANZIATORE
51	911432 00000	DISCO GIUOCO 25X33X0,2
52	911431 00000	DISCO GIUOCO 25X33X0,1
53	911429 00000	DISCO GIUOCO 25X33X0,05
54	911428 00000	DISCO GIUOCO 25X33X0,025
55	906612 50000	CUSCINETTO A SFERA
56	016800 30200	PULEGGIA DI TENSIONE
57	901805 00000	VITE ESAGONALE
63	000200 30200	COPERCHIO DELLA CARCASSA
64	951703 00000	DISCO A MOLLA
65	945325 00000	VITE ESAGONALE INTERNA
69	005600 30200	COPERCHIO
70	005602 30200	COPERCHIO
72	945222 00000	VITE ESAGONALE
75	001102 30200	CAPPELLO DEL CUSCINETTO
76	948503 00000	ANELLO A MOLLA
77	945215 00000	VITE ESAGONALE
78	928602 70000	MOLLA DI COMPRESSIONE
79	917520 00000	DISCO DI COMPENSAZIONE
101	007400 19600	CARCASSA SILENZIATORE
102	907600 60000	TUBO-CRIVELLO
103	907701 70000	MATERIALE PER SILENZIATORE
104	907500 30200	GIUNTO
105	007803 30200	FLANGIA FILETTATA
107	949451 00000	RONDELLA
108	003803 94000	CHIAVARDA D'ANCORAGGIO
109	903811 01000	CHIAVARDA D'ANCORAGGIO
113	040100 30200	CONTENITORE FILTRO A CARTUCCIA
115	945321 00000	VITE ESAGONALE INTERNA
116	945225 00000	VITE ESAGONALE
119	945376 00000	VITE ESAGONALE INTERNA
125	909568 00000	CARTUCCIA FILTRO (1x) ¹⁾
126	951007 00000	L'ASTA A VITE
127	040200 19700	COPERCHIO FILTRO
133	921503 00000	MANOPOLA A CROCIERA
135	040201 19700	COPERCHIO FILTRO
138	945373 00000	VITE ESAGONALE INTERNA
139	016600 19600	PEZZI RACCORDI
181	015500 30200	GIUNTO DI REDUZIONE
183	005601 30200	COPERCHIO
201	015100 30200	PIEDE
202	947504 00000	RONDELLA
203	945223 00000	VITE ESAGONALE
204	015101 30200	PIEDE-LATERALE
206	945320 00000	VITE ESAGONALE INTERNA
209	951906 00000	PROTEZIONE IN GOMMA
211	946944 00000	L'ASTA A VITE
213	012400 30200	PIASTRA INTERMEDIA
215	741315 00000	AMMORTIZZATORE IN GOMMA
216	015101 79000	PIASTRA DI APPOGGIO
301	007401 19600	CARCASSA SILENZIATORE

Pos.	No. Identificazione	Designazione
302	907600 70100	TUBO-CRIVELLO
303	907702 10000	MATERIALE PER SILENZIATORE
316	903803 01000	VITE
400.1	733700 99581	VALVOLA, < 0,17BAR
400.2	733701 99581	VALVOLA, < 0,28BAR
400.3	733702 99581	VALVOLA, < 0,42BAR

Variante	/1-05 /2-05		CON PROTEZIONE ANTI-CORROSIONE ²⁾
		570410 30200 69 005610 30200 181 015510 30200 183 005611 30200 570210 30200 27 000110 30200 49 000612 30200 63 000210 30200 70 005612 30200 574310 30200 113 040110 30200 301 007411 19600 574311 30200 113 040110 30200 139 016610 19600 301 007411 19600 573310 30200 101 007410 19600 574313 30200 113 040110 30200 139 016610 19600	SET DI TRASFORMAZIONE /1⇒ /2 - COPERCHIO - GIUNTO DI REDUZIONE - COPERCHIO SOFFIANTE / POMPA A VUOTO - CARCASSA - GIRANTE - COPERCHIO DELLA CARCASSA - COPERCHIO SILENZIATORE CON FILTRO - CARCASSA DEL FILTRO - CARCASSA SILENZIATORE SILENZIATORE CON VALVOLA - CARCASSA DEL FILTRO - PEZZO DI RACORDO - CARCASSA SILENZIATORE SILENZIATORE - CARCASSA SILENZIATORE SILENZIATORE CON VALVOLA + FILTRO - CARCASSA DEL FILTRO (2x) - PEZZO DI RACORDO

Variante	/1-401 /2-401		CON CONVERTITORE DI FREQUENZA ²⁾
		570500 30200 49 000603 30200 65 945254 00000 573304 30200 105 007801 30200 413 796302 41115 415 503603 41100	SOFFIANTE / POMPA A VUOTO - GIRANTE - RONDELLA SILENZIATORE - FLANGIA FILETTATA CONVERTITORE DI FREQUENZA (4,0KW) ADATTATORE PIATTO

¹⁾ quantità di ordinazione necessari / manutenzione (F / DSF / VSF)

²⁾ componenti variante-dipendenti

Disegno - vedere allegato



Pos.	No. De pedido	Descripción	
8	570400 30200	EQUIPO PARA LA CONVERSIÓN /1⇒ /2 (POS: 64, 69, 119, 181, 183)	
12	515101 30200	PIE - LATERAL, COMPLETO	
14	515103 30200	PIE, COMPLETO (3x) ¹⁾	
27	000100 30200	CARCASA	
29	911304 00000	MANGUERA DE JUNTA	
34	064900 30200	MANGUITO DE CENTRADO	
48	947738 00000	LENGÜETA DE AJUSTE	
49	000602 30200	RUEDA CORREDERA	
50	013900 30200	CASQUILLO DISTANCIADOR	
51	911432 00000	ARANDELA DISTANCIADORA 25X33X0,2	
52	911431 00000	ARANDELA DISTANCIADORA 25X33X0,1	
53	911429 00000	ARANDELA DISTANCIADORA 25X33X0,05	
54	911428 00000	ARANDELA DISTANCIADORA 25X33X0,025	
55	906612 50000	COJINETE DE RODAMIENTO	
56	016800 30200	POLEA TENSORA	
57	901805 00000	TORNILLO DE CABEZA HEXAGONAL	
63	000200 30200	CUBIERTA DE CARCASA	
64	951703 00000	ARANDELA ELÁSTICA	
65	945325 00000	TORNILLO HEXAGONAL INTERIOR	
69	005600 30200	TAPA	
70	005602 30200	TAPA	
72	945222 00000	TORNILLO DE CABEZA HEXAGONAL	
75	001102 30200	TAPA DEL COJINETE	
76	948503 00000	ARANDELA DE MUELLE	
77	945215 00000	TORNILLO DE CABEZA HEXAGONAL	
78	928602 70000	MUELLE DE PRESIÓN	
79	917520 00000	ARANDELA DE AJUSTE	
101	007400 19600	CARCASA DE SILENCIADOR	
102	907600 60000	TUBO DE CRIBA	
103	907701 70000	AMORTIGUADOR	
104	907500 30200	JUNTA	
105	007803 30200	BRIDA ROSCADA	
107	949451 00000	ARANDELA	
108	003803 94000	TORNILLO DE ANCLAJE	
109	903811 01000	TORNILLO DE ANCLAJE	
113	040100 30200	CARCASA DE FILTRO	
115	945321 00000	TORNILLO HEXAGONAL INTERIOR	
116	945225 00000	TORNILLO DE CABEZA HEXAGONAL	
119	945376 00000	TORNILLO HEXAGONAL INTERIOR	
125	909568 00000	CARTUCHO (1x) ¹⁾	
126	951007 00000	ESPÁRRAGO	
127	040200 19700	FILTRO TAPA	
133	921503 00000	EMPUÑADURA DE ESTRELLA	
135	040201 19700	TAPA DE FILTRO	
138	945373 00000	TORNILLO HEXAGONAL INTERIOR	
139	016600 19600	PIEZA DE EMPALME	
181	015500 30200	PIEZA DE REDUCCIÓN	
183	005601 30200	TAPA	
201	015100 30200	PIE	
202	947504 00000	ARANDELA	
203	945223 00000	TORNILLO DE CABEZA HEXAGONAL	
204	015101 30200	PIE DE APARATO - LATERAL	
206	945320 00000	TORNILLO HEXAGONAL INTERIOR	
209	951906 00000	BOQUILLA DE CABLE	
211	946944 00000	ESPÁRRAGO	
213	012400 30200	PIEZA INTERMEDIA	
215	741315 00000	AMORTIGUADOR DE GOMA	
216	015101 79000	PIE DE APARATO	
301	007401 19600	CARCASA DE SILENCIADOR	

Pos.	No. De pedido	Descripción	
302	907600 70100	TUBO DE CRIBA	
303	907702 10000	AMORTIGUADOR PANTARIN	
316	903803 01000	TORNILLO TIRANTE	
400.1	733700 99581	VÁLVULA, < 0,17BAR	
400.2	733701 99581	VÁLVULA, < 0,28BAR	
400.3	733702 99581	VÁLVULA, < 0,42BAR	

Variante	/1-05 /2-05	CON PROTECCIÓN CONTRA LA CORROSION ²⁾
	570410 30200	EQUIPO PARA LA CONVERSIÓN /1⇒ /2
69	005610 30200	- TAPA
181	015510 30200	- PIEZA DE REDUCCIÓN
183	005611 30200	- TAPA
	570210 30200	SOPLANTES / BOMBA DE VACIO
27	000110 30200	- CARCASA
49	000612 30200	- RUEDA CORREDERA
63	000210 30200	- TAPA DE CARCASA
70	005612 30200	- TAPA
	574310 30200	SILENCIADOR CON FILTRO
113	040110 30200	- CARCASA DE FILTRO
301	007411 19600	- CARCASA DE SILENCIADOR
	574311 30200	SILENCIADOR CON VÁLVULA
113	040110 30200	- CARCASA DE FILTRO
139	016610 19600	- PIEZA DE EMPALME
301	007411 19600	- CARCASA DE SILENCIADOR
	573310 30200	SILENCIADOR
101	007410 19600	- CARCASA DE SILENCIADOR
	574313 30200	SILENCIADOR CON VÁLVULA + FILTRO
113	040110 30200	- CARCASA DE FILTRO (2x)
139	016610 19600	- PIEZA DE EMPALME

Variante	/1-401 /2-401	CON CONVERTIDOR DE FRECUENCIA ²⁾
	570500 30200	SOPLANTES / BOMBA DE VACIO
49	000603 30200	- RUEDA CORREDERA
65	945254 00000	- ARANDELA
	573304 30200	SILENCIADOR
105	007801 30200	- BRIDA ROSCADA
413	796302 41115	CONVERTIDOR DE FRECUENCIA (4,0KW)
415	503603 41100	PLACA ADAPTADORA

¹⁾ cantidad necesario / mantenimiento (F / DSF / VSF)

²⁾ componentes variante-dependientes

Dibujo - véase apéndice



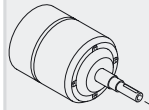

SERVICE ?

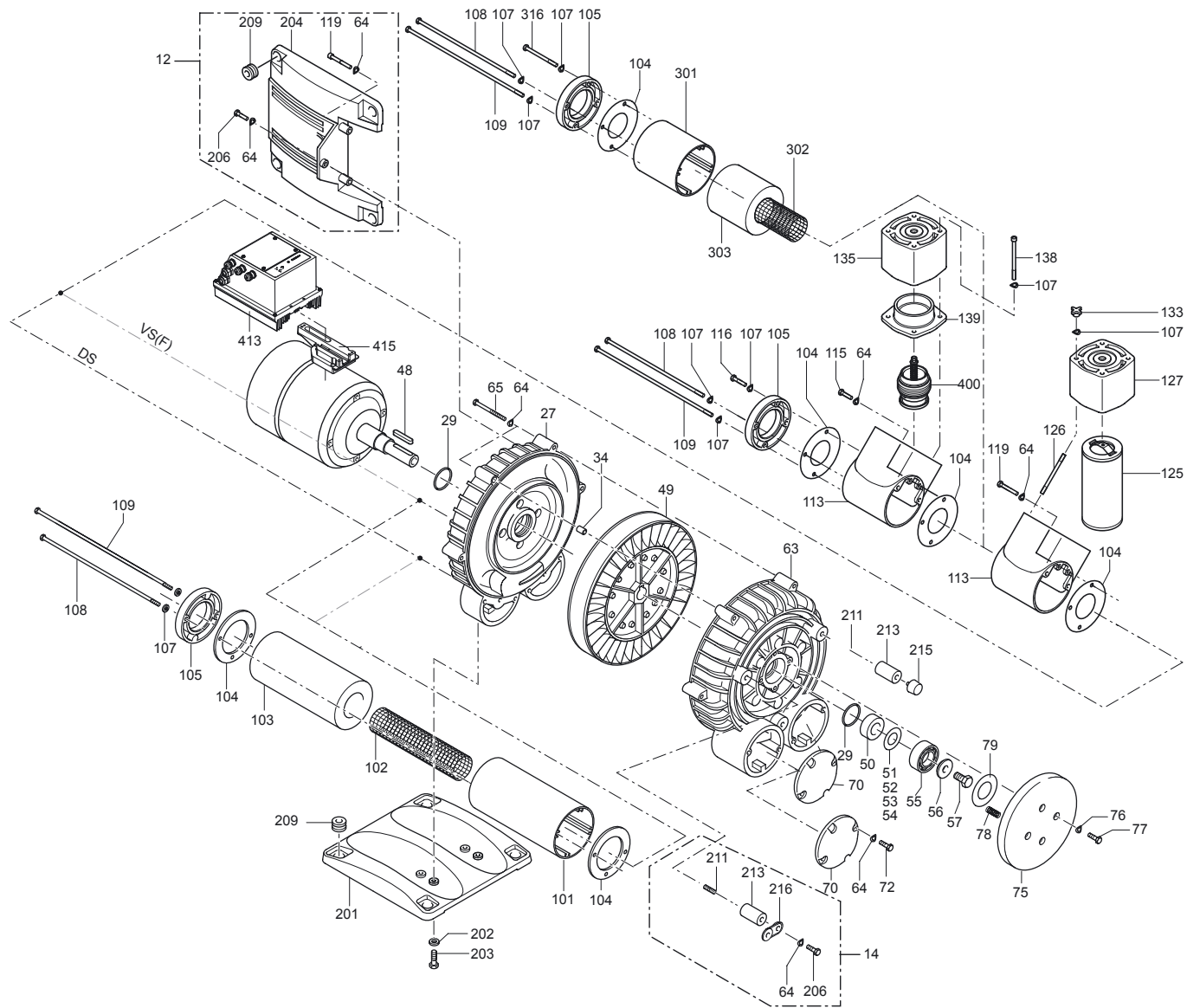
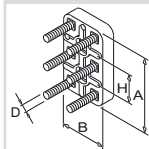
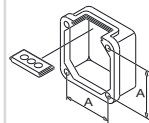
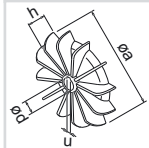
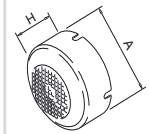

SV 8.130/1



SV 8.130/2

SV 8.130/2



SV 8.130/5

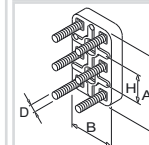
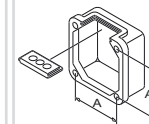
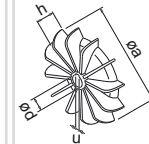
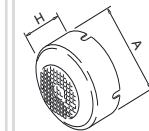
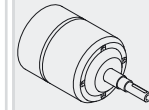
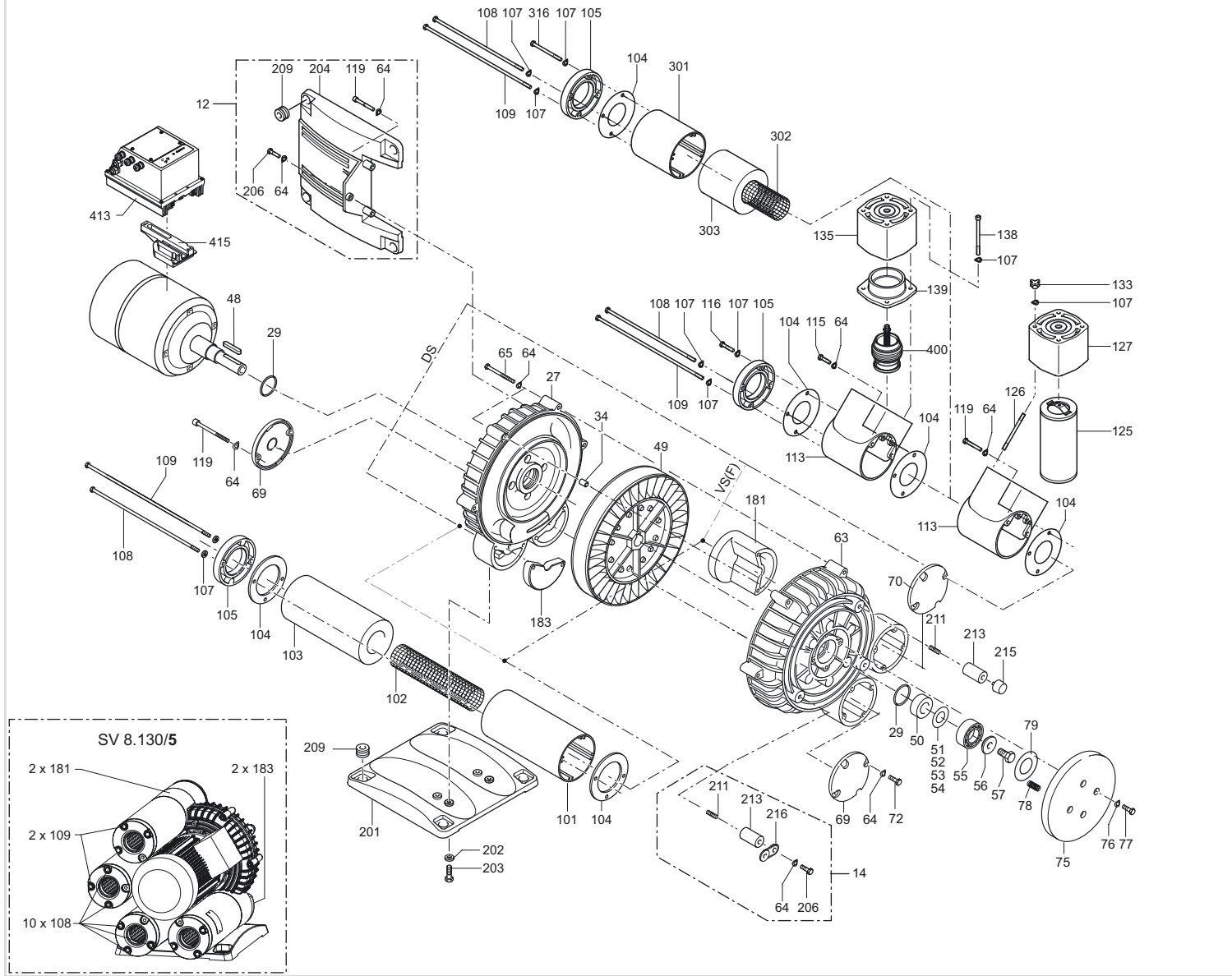

SV 8.130/1