

SV 5.1050

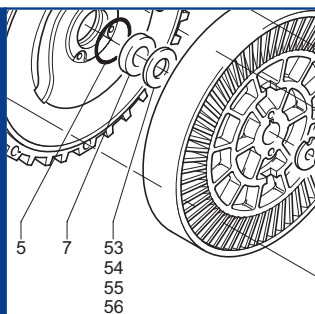

SERVICE

BECKER
D-42279 Wuppertal
www.becker-international.com

year

No **B** Index Variante

type **SV 5.1050-XX**

frequency	XXXX	Hz
speed	XXXX	min ⁻¹
power required	XXXX	kW
inlet capacity	XXXX	m ³ /h
pressure +	XXXX	mbar
vacuum -	XXXX	mbar

Made in Germany

Ersatzteilliste
Spare parts list
Liste de pièces de rechange
Listino pezzi di ricambio
Lista de piezas de recambio
 Lista de peças sobresselentes
 Reserveonderdelenlijst
 Atsarginių dalių sąrašas
 Varuosad nimekirja
 Rezerves daļu saraksts

Reservedelsliste
Reservdelslista
Varaosuettelo
Reservedelsliste
Wykaz części zamiennych
Tartalékalkatrész lista
Seznam náhradních dílů
Seznam nadomestnih delov
Zoznam náhradných dielov
Rezervni dijelovi popis

Lista pieselor de schimb
Páirteanna spártha liosta
Κατάλογος ανταλλακτικών
Yedek parça listesi
Списък на резервните части
Перечень запасных частей
スペアパーツリスト
예비 부품 목록
备用零件目录

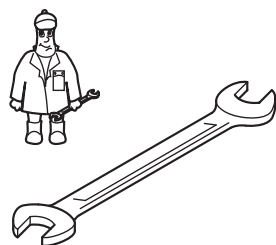

Wartung
Maintenance
Entretien
Manutenzione
Mantenimiento

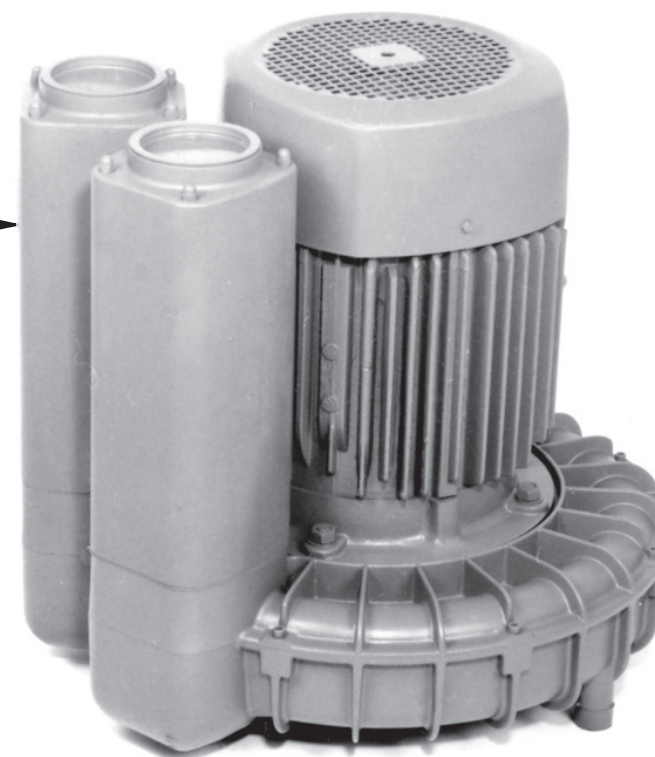

SERVICE
www.becker-international.com
 Sales and service network

SV 5.1050 Standard

Variante

SV 5.1050/-XX

① /1-05
 Korrosionsschutz / ohne Fuß
 corrosion protection / without foot
 protection contre la corrosion
 protezione anti-corrosione
 protección contra la corrosión

② /1-30
 ohne Schalldämpfer
 without silencer
 sans silencieux
 senza silenziatore
 sin silenciador

③ /1-48
 Sonderausführung
 Special design
 Fabrication spéciale
 Modello speciale
 Versión especial

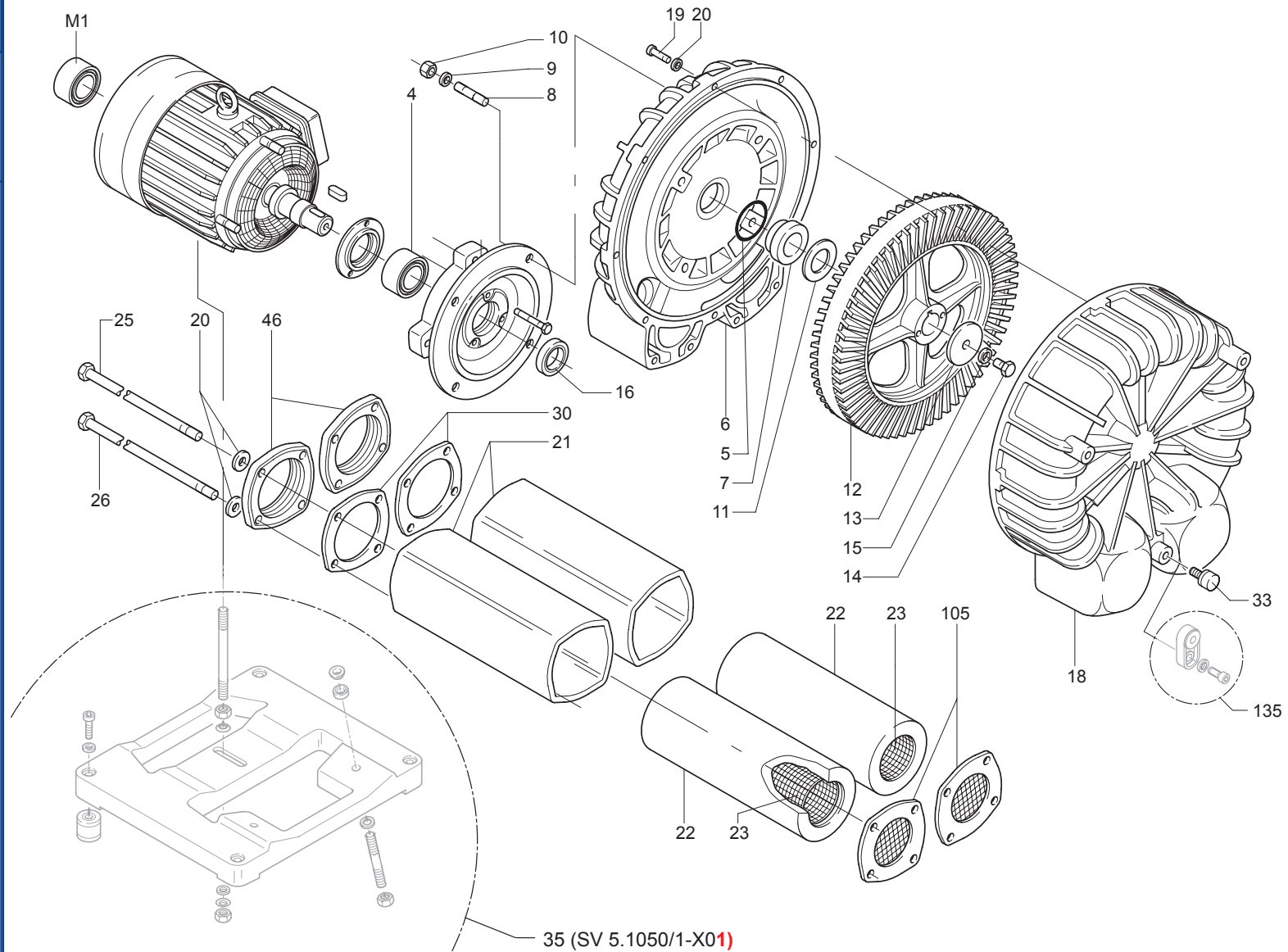
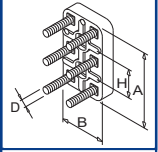
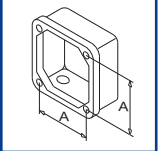
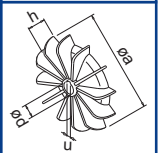
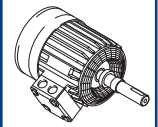
SERVICE

B INDEX	Pos.	Bestell Nr.	Beschreibung	
SV 5.1050	4	906611 10000	WÄZLAGER 3208 2 RS C3 TA	
	5	911317 00000	DICHTUNGSSCHLAUCH	
	6	000101 16900	GEHÄUSE	
	7	013901 16900	DISTANZBUCHSE	
	8	946937 00000	STIFTSCHRAUBE	
	9	951705 00000	FEDERSCHEIBE	
	10	947107 00000	SECHSKANTMUTTER	
	11	511400 16600	SATZ DISTANZSCHEIBEN	
	12	000600 16900	LAUFRAD	
	13	016800 16900	SPANNSCHEIBE	
14	945243 00000	SECHSKANTSCHRAUBE		
15	948509 00000	FEDERRING		
16	906578 00000	WELLENDICHTRING		
18	000200 16900	GEHÄUSEDECKEL		
19	945363 00000	INNENSECHSKANTSCHRAUBE		
20	951703 00000	FEDERSCHEIBE		
21	007420 16900	SCHALLDÄMPFERGEHÄUSE		
22	007700 16900	DÄMPFER		
23	907610 16900	SIEBROHR		
25	003801 16900	ZUGANKERSCHRAUBE		
26	003803 16800	ZUGANKERSCHRAUBE		
30	007500 16900	DICHTUNG		
33	741310 10000	GUMMIPUFFER		
35	515100 16800	GERÄTEFUSS, KOMPL. / BG132 ¹⁾		
35	515101 16800	GERÄTEFUSS, KOMPL. / BG160 ¹⁾		
46	007800 16900	ANSCHLUSSFLANSCH		
105	507500 16900	DICHTUNG		
M1	906639 00000	MOTORLAGER 6306 ²⁾		
M1	906635 00000	MOTORLAGER 6308 ²⁾		
M1	906616 40000	MOTORLAGER 6208 ²⁾		
M1	906615 50000	MOTORLAGER 6309 ²⁾		
M1	906615 70000	MOTORLAGER 6310 ²⁾		

¹⁾ optional

²⁾ motorabhängig / Lager sind mit Spezialfett gefüllt. Nur durch Original der Firma Gebr. Becker ersetzen.

B INDEX	Pos.	Ident No.	Description	
SV 5.1050	4	906611 10000	BALL BEARING 3208 2 RS C3 TA	
	5	911317 00000	SEAL	
	6	000101 16900	PUMP BODY	
	7	013901 16900	SPACER	
	8	946937 00000	STUD	
	9	951705 00000	SPRING DISC	
	10	947107 00000	HEX. NUT	
	11	511400 16600	SET DISTANCE DISC	
	12	000600 16900	IMPELLER	
	13	016800 16900	CLAMPING DISC	
14	945243 00000	HEX-HEAD SCREW		
15	948509 00000	SPRING WASHER		
16	906578 00000	SHAFT-SEALING RING		
18	000200 16900	HOUSING LID		
19	945363 00000	SOCKET HEAD SCREW		
20	951703 00000	LOCKING WASHER		
21	007420 16900	SILENCER HOUSING		
22	007700 16900	SILENCER SPONGE		
23	907610 16900	STRAINER TUBE		
25	003801 16900	ANCHORING SCREW		
26	003803 16800	ANCHORING SCREW		
30	007500 16900	GASKET		
33	741310 10000	RUBBER BUFFER		
35	515100 16800	FOOT, COMPL. / BG132 ¹⁾		
35	515101 16800	FOOT, COMPL. / BG160 ¹⁾		
46	007800 16900	CONNECTING FLANGE		
105	507500 16900	GASKET		
M1	906639 00000	BALL BEARING 6306 ²⁾		
M1	906635 00000	BALL BEARING 6308 ²⁾		
M1	906616 40000	BALL BEARING 6208 ²⁾		
M1	906615 50000	BALL BEARING 6309 ²⁾		
M1	906615 70000	BALL BEARING 6310 ²⁾		

¹⁾ optional

²⁾ motor-dependent / Bearings are filled with special grease. Only be replaced by Gebrüder Beckers original.

B INDEX	Pos.	No. Identification	Designation		
SV 5.1050	4	906611 10000	ROULEMENT A BILLES 3208 2 RS C3 TA		
	5	911317 00000	JOINT		
	6	000101 16900	CORP DE POMPE		
	7	013901 16900	DOUILLE		
	8	946937 00000	PRISONNIER		
	9	951705 00000	DISQUE DE RESSORT		
	10	947107 00000	ECROU A 6 PANS		
	11	511400 16600	JEU DISQUE DE TOLERANCE		
	12	000600 16900	ROUE		
	13	016800 16900	DISQUE DE SERRAGE		
14	945243 00000	VIS HEXAGONALE			
15	948509 00000	ANNEAU-RESSORT			
16	906578 00000	BAGUE D'ETANCHEITE P.L'AXE			
18	000200 16900	COUVERCLE			
19	945363 00000	VIS HEXAGONALE INTERNE			
20	951703 00000	RONDELLE À RESSORT			
21	007420 16900	CARCASSE SILENCIEUX			
22	007700 16900	MOUSSE POUR SILENCIEUX			
23	907610 16900	GRILLE POUR SILENCIEUX			
25	003801 16900	VIS D'ANCRAGE			
26	003803 16800	VIS D'ANCRAGE			
30	007500 16900	JOINT			
33	741310 10000	AMORTISSEUR EN CAOUTCHOUC			
35	515100 16800	PIED, COMPL. / BG132 ¹⁾			
35	515101 16800	PIED, COMPL. / BG160 ¹⁾			
46	007800 16900	BRIDE DE RACCORDEMENT			
105	507500 16900	JOINT			
M1	906639 00000	ROULEMENT A BILLES 6306 ²⁾			
M1	906635 00000	ROULEMENT A BILLES 6308 ²⁾			
M1	906616 40000	ROULEMENT A BILLES 6208 ²⁾			
M1	906615 50000	ROULEMENT A BILLES 6309 ²⁾			
M1	906615 70000	ROULEMENT A BILLES 6310 ²⁾			

¹⁾ en option
²⁾ dépendant du moteur / Les roulements sont remplis d'une graisse spéciale. N'utiliser que de la graisse d'origine de Gebrüder Becker.

B INDEX	Pos.	No. Identificazione	Designazione		
SV 5.1050	4	906611 10000	CUSCINETTO A SFERA 3208 2 RS C3 TA		
	5	911317 00000	GUARNIZIONE		
	6	000101 16900	CARCASSA		
	7	013901 16900	BOCCOLA		
	8	946937 00000	L'ASTA A VITE		
	9	951705 00000	DISCO A MOLLA		
	10	947107 00000	DADO ESAGONALE		
	11	511400 16600	SERIE DISCO GIUOCO		
	12	000600 16900	GIRANTE		
	13	016800 16900	DISCO DI FISSAGGIO		
14	945243 00000	VITE ESAGONALE			
15	948509 00000	ANELLO A MOLLA			
16	906578 00000	GUARNIZIONE PER L'ALBERO			
18	000200 16900	COPERCHIO			
19	945363 00000	VITE ESAGONALE INTERNA			
20	951703 00000	DISCO A MOLLA			
21	007420 16900	CARCASSA SILENZIATORE			
22	007700 16900	MATERIALE PER SILENZIATORE			
23	907610 16900	TUBO-CRIVELLO			
25	003801 16900	CHIAVARDA D'ANCORAGGIO			
26	003803 16800	CHIAVARDA D'ANCORAGGIO			
30	007500 16900	GUARNIZIONE			
33	741310 10000	AMMORTIZZATORE IN GOMMA			
35	515100 16800	PIASTRA DI APPOGGIO, COMPL. / BG132 ¹⁾			
35	515101 16800	PIASTRA DI APPOGGIO, COMPL. / BG160 ¹⁾			
46	007800 16900	FLANGIA DI RACCORDO			
105	507500 16900	GUARNIZIONE			
M1	906639 00000	CUSCINETTO A SFERA 6306 ²⁾			
M1	906635 00000	CUSCINETTO A SFERA 6308 ²⁾			
M1	906616 40000	CUSCINETTO A SFERA 6208 ²⁾			
M1	906615 50000	CUSCINETTO A SFERA 6309 ²⁾			
M1	906615 70000	CUSCINETTO A SFERA 6310 ²⁾			

¹⁾ optionale
²⁾ dipende del motore / I cuscinetti sono riempiti di grasso speciale. Eseguire il reingrassaggio solo con grasso originale della Gebrüder Becker.

B INDICE	Pos.	No. De pedido	Descripción	
SV 5.1050	4	906611 10000	COJINETE DE RODAMIENTO 3208 2 RS C3 TA	
	5	911317 00000	MANGUERA DE JUNTA	
	6	000101 16900	CARCASA	
	7	013901 16900	CASQUILLO DISTANCIADOR	
	8	946937 00000	ESPÁRRAGO	
	9	951705 00000	ARANDELA ELÁSTICA	
	10	947107 00000	TUERCA HEXAGONAL	
	11	511400 16600	JUEGO DE ARANDELAS DISTANCIADORAS	
	12	000600 16900	RUEDA CORREDERA	
	13	016800 16900	ARANDELA TENSORA	
	14	945243 00000	TORNILLO DE CABEZA HEXAGONAL	
	15	948509 00000	ARANDELA DE MUELLE	
	16	906578 00000	ANILLO DE JUNTA DE ÁRBOL	
	18	000200 16900	TAPA DE CARCASA	
	19	945363 00000	TORNILLO HEXAGONAL INTERIOR	
	20	951703 00000	ARANDELA ELÁSTICA	
	21	007420 16900	CARCASA DE SILENCIADOR	
	22	007700 16900	AMORTIGUADOR	
	23	907610 16900	TUBO DE CRIBA	
	25	003801 16900	TORNILLO DE ANCLAJE	
	26	003803 16800	TORNILLO DE ANCLAJE	
	30	007500 16900	JUNTA	
	33	741310 10000	AMORTIGUADOR DE GOMA	
	35	515100 16800	PIE DE APARATO, COMPL. / BG132 ¹⁾	
	35	515101 16800	PIE DE APARATO, COMPL. / BG160 ¹⁾	
	46	007800 16900	BRIDA DE EMPALME	
	105	507500 16900	JUNTA	
	M1	906639 00000	COJINETE DE RODAMIENTO 6306 ²⁾	
	M1	906635 00000	COJINETE DE RODAMIENTO 6308 ²⁾	
	M1	906616 40000	COJINETE DE RODAMIENTO 6208 ²⁾	
	M1	906615 50000	COJINETE DE RODAMIENTO 6309 ²⁾	
M1	906615 70000	COJINETE DE RODAMIENTO 6310 ²⁾		

¹⁾ opcional
²⁾ dependiente del motor / Los rodamientos estan rellenos de grasa especial. Sólo reemplazar por grasa original de Gebrüder Becker.

SV5.1050/-XX Variante 	Pos. ²⁾	Bestell Nr. / Ident No. / No. Identification / No. Identificazione / No. De pedido		Beschreibung / Description / Designation / Designazione / Desripcion
① /1-05 Korrosionsschutz corrosion protection protection contre la corrosion protezione anti-corrosione protección contra la corrosión	6	000111 16900	000100 16900	GEHÄUSE / PUMP BODY / CORP DE POMPE / CARCASSA / CARCASA
	12	000610 16900	000600 16900	LAUFRAD / IMPELLER / ROUE / GIRANTE / RUEDA CORREDERA
	13	016810 16900	016800 16900	SPANNSCHEIBE / CLAMPING DISC / DISQUE DE SERRAGE / DISCO DI FISSAGGIO / ARANDELA TENSORA
	18	000210 16900	000200 16900	GEHÄUSEDECKEL / HOUSING LID / COUVERCLE / COPERCHIO / TAPA DE CARCASA
	21	007413 16900	007420 16900	SCHALLDÄMPFERGEHÄUSE / SILENCER HOUSING / CARCASSE SILENCIEUX / CARCASSA SILENZIATORE / CARCASA DE SILENCIADOR
	23	007610 16900	007610 16900	SIEBROHR / STRAINER TUBE / GRILLE POUR SILENCIEUX / TUBO-CRIVELLO / TUBO DE CRIBA
② /1-30 ohne Schalldämpfer without silencer sans silencieux senza silenziatore sin silenciador	12	000602 16900	000600 16900	LAUFRAD / IMPELLER / ROUE / GIRANTE / RUEDA CORREDERA
	21		007420 16900	SCHALLDÄMPFERGEHÄUSE / SILENCER HOUSING / CARCASSE SILENCIEUX / CARCASSA SILENZIATORE / CARCASA DE SILENCIADOR
	22		007700 16900	DÄMPFER / SILENCER SPONGE / MOUSSE POUR SILENCIEUX / MATERIALE PER SILENZIATORE / AMORTIGUADOR
	23		007610 16900	SIEBROHR / STRAINER TUBE / GRILLE POUR SILENCIEUX / TUBO-CRIVELLO / TUBO DE CRIBA
	25		003801 16900	ZUGANKERSCHRAUBE / ANCHORING SCREW / VIS D'ANCRAGE / CHIAVARDA D'ANCORAGGIO / TORNILLO DE ANCLAJE
	26		003803 16900	ZUGANKERSCHRAUBE / ANCHORING SCREW / VIS D'ANCRAGE / CHIAVARDA D'ANCORAGGIO / TORNILLO DE ANCLAJE
	27		951703 00000	FEDERSCHEIBE / LOCKING WASHER / RONDELLE À RESSORT / DISCO A MOLLA / ARANDELA ELÁSTICA
	30		007500 16900	DICHTUNG / GASKET / JOINT / GUARNIZIONE / JUNTA
	33		741310 10000	GUMMIPUFFER / RUBBER BUFFER / AMORTISSEUR EN CAOUTCHOUC / AMMORTIZZATORE IN GOMMA / AMORTIGUADOR DE GOMA
	46		007800 16900	ANSCHLUSSFLANSCH / CONNECTING FLANGE / BRIDE DE RACCORDEMENT / FLANGIA DI RACCORDO / BRIDA DE EMPALME
	50	062900 16900		ABDECKUNG / COVERING / REVÊTEMENT / RIVESTIMENTO / RECUBRIMIENTO
	54	945320 00000		INNENSECHSKANTSCHRAUBE / SOCKET HEAD SCREW / VIS HEXAGONALE INTERNE / VITE ESAGONALE INTERNA / TORNILLO HEXAGONAL INTERIOR
③ /1-48 Sonderausführung Special design Fabrication spéciale Modello speciale Versión especial	12	000601 16900	000600 16900	LAUFRAD / IMPELLER / ROUE / GIRANTE / RUEDA CORREDERA

²⁾ variantenabhängige Bauteile / variant-dependent components / composants variante-dependantes / componenti variante-dispendenti / componentes variante-dependientes